

2190 Dagenais Blvd. West Tel. : 514.337.4415
 Laval (Quebec) Fax : 514.337.4029
 Canada info@burcam.com
 H7L 5X9 see us at www.burcam.com

JET PUMPS

MODELS

506321/506721
 (VERSION W 2015)

AND OTHER PRODUCTS

506327	506727
506328	506728
506331	506731
	etc.

Your pump has been carefully packaged at the factory to prevent damage during shipping. However, occasional damage may occur due to rough handling. **Carefully inspect your pump** for damages that could cause failures. Report any damage to your carrier or your point of purchase.

Please read these instructions carefully. **Failure** to comply to instructions and **designed** operation of this system, may **void** the warranty.

READ THIS DOCUMENT IN TOTALITY PRIOR TO STARTING THE INSTALLATION.

FACTORY SET VOLTAGE 115 V TO CHANGE THE VOLTAGE :

Before changing the voltage connection:

- A) Ensure the power to the pump is disconnected.
- B) Open motor junction box cover.
- C) Please select the up knob position for 115V or down knob position for 230V.
- D) Close motor junction box.
- E) Connect to appropriate voltage at pressure switch.

PRIMING PROCESS

Follow all these step by step instructions to install your pump. Use teflon tape on all threads. (1) Fill the suction line with water and connect it to the suction inlet. (2) Remove the priming plug and fill the pump body with water. (3) Screw the plug to the priming inlet. (4) Turn the power on. The pump should deliver water to the plumbing line within 30 seconds. If not, unplug the pump and repeat the process at step 2.

1" Discharge connection

2-3

1" Suction connection

4

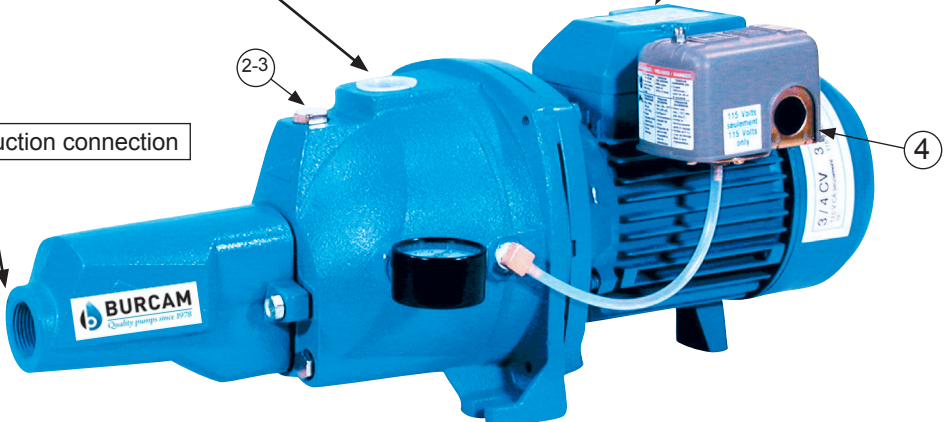

SAFETY INSTRUCTIONS :

This fine pump that you have just purchased is designed from the latest in material and workmanship.

Before installation and operation, we recommend the following procedures :

A

Check with your local electrical and plumbing codes to ensure you comply with the regulations. These codes have been designed with your safety in mind. Be sure you comply with them.

B

We recommend that the pump be used on a separate circuit lead from the home electrical distribution panel, and which is protected with a fuse or a circuit breaker. The motor must be securely plugged into a proper 'GFCI' electrical outlet. Consult a licensed electrician for all wiring.

C

The ground terminal on the three prong plugs should never be removed. They are supplied and designed for your protection.

D

Never make adjustments to any electrical appliance or product with the power connected. Do not only unscrew the fuse or trip the breaker, remove the power plug from the receptacle.

MONTHLY MANDATORY CHECK-UP :

1. Inspect the pump for any obvious condition that necessitates cleaning, correction, adjustment or repair.
2. Clear the surroundings of any paper, leaves or other debris.
3. Ensure that the pump is secure for proper operation.
4. Ensure that there is adequate clearance from any combustible materials or structure. Stored materials must be kept away from the pump. Shelves or cabinet structures must not be in close proximity to the pump.
5. Ensure that the motor is securely plugged into a proper 'GFCI' electrical outlet.
6. Test the 'GFCI' outlet by pressing its test switch. This should prove that the outlet is energized and will trip off to protect against a ground fault. Be sure to reset the 'GFCI' by pressing its reset switch.
7. Observe that the plumbing can carry the water safely into the residence.

Material required for drilled well application (indoor use only)

Shallow well pump installation

- Desired length of polyethylene 1" pipe, 100 PSI, CSA or UL approved, to link up from pumping level to pump.
- 1 1" foot valve (750756 or 750752P).
- 1 well seal, as per well casing diameter (750929 6" x 1").
- 1 1" well seal elbow (750860).
- 2 1" male adaptors (750865 or 750871).
- 8 1" stainless steel clamps (750885).
- Teflon tape.

Tank installation

- Desired length of 1" braided hose (750919) to link up from pump to tank. Keep tank as close as possible from pump.
- 1 tank T (650651).
- 1 drain valve (650659).
- 2 1" female adaptor.
- 1 1" male adaptor (750865 or 750871).
- 3 1" stainless steel clamps (750885).
- Teflon tape.

Deep well pump installation

- Desired length of polyethylene 1 and 1/4" pipe, 100 PSI, CSA or UL approved, to link up from pumping level to pump.
- 1 1" foot valve (750756 or 750752P).
- 1 well seal, as per well casing diameter (750926 6" x 1 1/4" x 1").
- 1 1" well seal elbow (750860).
- 1 1 1/4" well seal elbow (750861).
- 1 1 1/4" venturi adaptor (750864).
- 2 1" male adaptors (750865 or 750871).
- 1 1 1/4" male adaptor (750872).
- 8 1" stainless steel clamps (750885).
- 8 1/4" stainless steel clamps (750886).
- Teflon tape.

Tools

Screwdrivers, hacksaw to cut pipe, knife to assist in pipe cutting, round file to smooth pipe ends, pipe wrench, adjustable wrench to tighten fittings, propane torch and welding material.

APPLICATION :

- ❑ This pump is designed for shallow well installation for water level up to 25 feet with injector screwed on pump body; or for deep well installation for water level up to 70 feet, with 2 pipes and injector down in the well.

❑ CAPACITIES :

SHALLOW WELL

	1/2 CV	3/4 CV
25'	280	310
5'	805	820
	US GPH	

DEEP WELL

	1/2 CV	3/4 CV
70'	185	215
50'	650	685
	US GPH	

Friction loss in pipe not included.

FEATURES :

- ❑ High performance Noryl impeller.
- ❑ Industrial motor totally enclosed, fan-cooled.
- ❑ Full-time connected run capacitor, to eliminate starting wear vs regular motor.
- ❑ Thermal and overload protection.
- ❑ Built for continuous use.
- ❑ 1/2 HP, 115/230VAC, 60Hz, 8.0/4.0A (16/8.0A when the pump start).
- ❑ 3/4 HP, 115/230VAC, 60Hz, 9.0/4.5A (18/9.0A when the pump start).

For factory assembled pump and tank system, skip step 9.

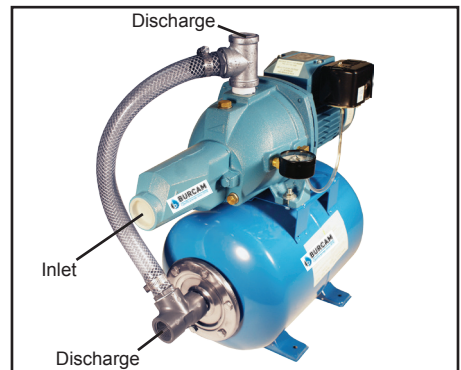

INSTALLATION STEPS

STEP 1

We recommend that you install your pump in a clean and dry location where there is adequate room for servicing at a later date. Protection from freezing temperatures and good ventilation should be considered as well, to provide the pump an environment for long life. Locating the pump as close as possible to the water source will reduce friction losses encountered in the suction pipe.

Friction losses in the suction pipe must be taken into consideration when the horizontal offset is greater than 50 feet. The suction pipes should be increased from 1" to 1/4". This will reduce friction losses and allow the pump to give maximum performance.

A new well should be checked to determine that it is free from sand. Sand will damage the seal and the impeller. Have your well driller clean the well before your installation.

Never run the pump dry. Damage to the seal may occur. Fill pump body and suction pipe with water before turning on the power.

THE RUN OF THE HORIZONTAL PIPE FROM THE TOP OF YOUR WELL INTO THE HOUSE, WHERE YOUR PUMP WILL BE LOCATED, MUST BE INSTALLED IN A TRENCH, BELOW THE FROST LEVEL OF YOUR AREA.

SHALLOW WELL APPLICATION

SEE DIAGRAM ON PAGE 8

STEP 2

Cut the desired length of poly pipe to run from the top of the well to the pumping level. Smooth the pipe cuttings with your round file. (Check that no cut-out parts are left inside of pipe. This may block pump injector or impeller).

Tape male adaptor threads with teflon tape and thread adaptor into the foot valve. Slide 2 stainless steel clamps over one end of pipe and use torch to soften pipe. Insert the male adaptor and foot valve into this pipe end. Tighten clamps with screwdriver. **For security against leaks, we suggest to install 2 stainless steel clamps on each adaptor.**

STEP 3

Insert the well seal elbow thru the opening of the seal.

Slide 2 stainless steel clamps over the free end of the previously cut pipe and soften pipe with your torch. Attach pipe to the well seal elbow (end protruding at bottom of well seal). Tighten clamps with screwdriver when cool.

STEP 4

Install the well seal and piping assembly into your well casing. Tight down the seal bolts using your adjustable wrench.

To facilitate servicing at a later date, you may use a pitless adaptor and a sealed well cap instead of an elbow and a well seal as described in steps 3 and 4.

STEP 5

Install your pump in the house, on a sound foundation, as close as possible to the basement wall. Thread an adaptor into inlet using teflon tape. Do not over tighten.

STEP 6

Cut the desired length of pipe from pump location to the well seal and connect both ends using the previous way, with stainless steel clamps and torch. Before connecting your pipe to the pump, fill the suction line with water. **Do not fill in your trench to the house until you have checked for any leaks in your connections or trouble in your water system.**

STEP 7 for sand or well point

Sand or well points are limited to areas where water bearing sand or gravel lies below the surface, and where there are no boulders or rocks to interfere with the driving into the ground of the point.

The amount of water any "one" well point will supply is usually rather limited. Sometimes, it is necessary to use more than one point to increase the supply of water entering to the pump's suction.

THE IMPORTANT INSTALLATION STEP IN USING WELL POINTS IS THAT A CHECK VALVE MUST BE USED IN THE SUCTION PIPE LEADING TO THE SUCTION INLET, AS CLOSE TO THE PUMP AS POSSIBLE, TO KEEP LINE AND PUMP WELL PRIMED.

CONTINUE ON PAGE 6 FOR TANKS
AND ON PAGE 7 FOR ELECTRICAL INSTALLATION STEPS.

DEEP WELL APPLICATION

SEE DIAGRAM ON PAGE 9

STEP 2

Locate your injector body fixed to the pump body and remove it. Using teflon tape, screw the 1 1/4" venturi adaptor (750864) over the injector venturi tube, into the 1 1/4" opening of injector body. Install the 1" male thread adaptor in the 1" opening in injector body. Securely tighten both adaptors with pipe wrench.

STEP 3

With teflon tape on threads, install a 1" nipple into the 1" foot valve, then screw this assembly into the 1" bottom opening of the injector.

STEP 4

Cut the desired length of 1" and 1 1/4" poly pipes to run from the top of the well to the pumping level. Smooth the pipe cuttings with your round file. (Check that no cut-out parts are left inside of pipe. This may block pump injector or impeller). Slide 2 stainless steel clamps over one end of each pipe and use torch to soften pipe. Fix the 1" and 1 1/4" pipes respectively on the 1" adaptor and 1 1/4" venturi adaptor. Tighten clamps with screwdriver when cool. **For security against leaks, we suggest that you install 2 stainless steel clamps on each adaptor.**

STEP 5

Insert both well seal elbows through their opening of the seal. Slide 2 stainless steel clamps over the free ends of the previously cut pipes and soften pipes with your torch. Attach pipes to the well seal elbows (ends protruding at bottom of well seal). Tighten clamps with screwdriver when cool.

STEP 6

Install the well seal and the ejector piping assembly into your well casing. Tighten down the well seal bolts using your adjustable wrench.

To facilitate servicing at a later date, you may use a pitless adaptor and a sealed well cap instead of an elbow and a well seal as described in steps 3 and 4.

STEP 7

Install your pump in the house, on a sound foundation, as close as possible to the basement wall. Locate the openings in the front of the pump body. Thread respectively 1" and 1 1/4" adaptors into corresponding openings using teflon tape. Do not over tighten.

STEP 8

Cut the desired length of pipes from pump location to the well seal and connect both ends using the previous way, with stainless steel clamps and torch. **Do not fill in your trench to the house until you have checked for any leaks in your connections or trouble in your water system.**

CONTINUE ON PAGE 6 FOR TANKS
AND ON PAGE 7 FOR ELECTRICAL INSTALLATION STEPS.

TANK INSTALLATION

SEE DIAGRAM ON PAGE 10

STEP 9 for captive air tanks

Packaged systems have the pump mounted directly to the tank. The pump to tank plumbing fittings are pre-assembled at the factory. You only have to connect the discharge line of your system to your home's plumbing distribution line. When using a separate tank from your pump, we recommend that you install a captive air tank as shown in our typical installation diagram. That has been pressurized with air in the tank. This air pressure inside the tank, which is in addition to atmospheric pressure, increases the ability of the tank to deliver more water between on/off cycles, thus increasing the efficiency of your water system. Connect the pump discharge to the tank T, using adaptors and braided hose, then, connect the other side of tank T to your home's plumbing distribution line.

Make sure that the precharged air pressure (before connecting the tank) is 2 PSI less than the starting pressure setting on the pressure switch of your pump.

If you adjust the air pressure after the installation, follow these steps:

- Check the starting pressure of the pump on the pressure gauge;
- Disconnect the power to the pump;
- Open nearest faucet to the tank and relieve all pressure in tank, then close the faucet;
- Adjust the air pressure of the tank (by pumping or removing air at the sniffer valve) to 2 PSI below the pressure switch "ON" setting;
- Turn power back on to pump.

Your tank is now properly precharged. Run the pump through a few cycles to verify that it works properly.

For epoxy or glass lined tanks

Other types of tanks may be used, such as galvanized standard tanks, epoxy or glass lined tanks. These products do not achieve the benefits of the captive air tanks.

Epoxy or glass lined tanks with a float have to be precharged by the installer. Assuming tank is plumbed to pump and all connections are checked for leaks, follow these steps:

- Run pump through one complete cycle, until pump shuts off;
- Disconnect the power to the pump;
- Open nearest faucet to the tank and relieve all pressure in tank, then close the faucet;
- Close service line gate valve;
- With a car tire pump, inject air into the sniffer valve located in tank. Watch the pump pressure gauge and stop pumping air when the pressure reaches 2 PSI below pressure the switch "ON" setting;
- Return power back on to pump;
- Run pump through one complete cycle;
- Open service line gate valve.

Your tank is now properly precharged. Run the pump through a few cycles to verify that it works properly.

Not recommended for galvanized tanks

Galvanized standard tanks require an air volume control to be used with a jet pump. We do not recommend the installation of this type of tank with your jet pump. This type of galvanized tank is recommended for piston pumps.

ELECTRICAL INSTALLATION

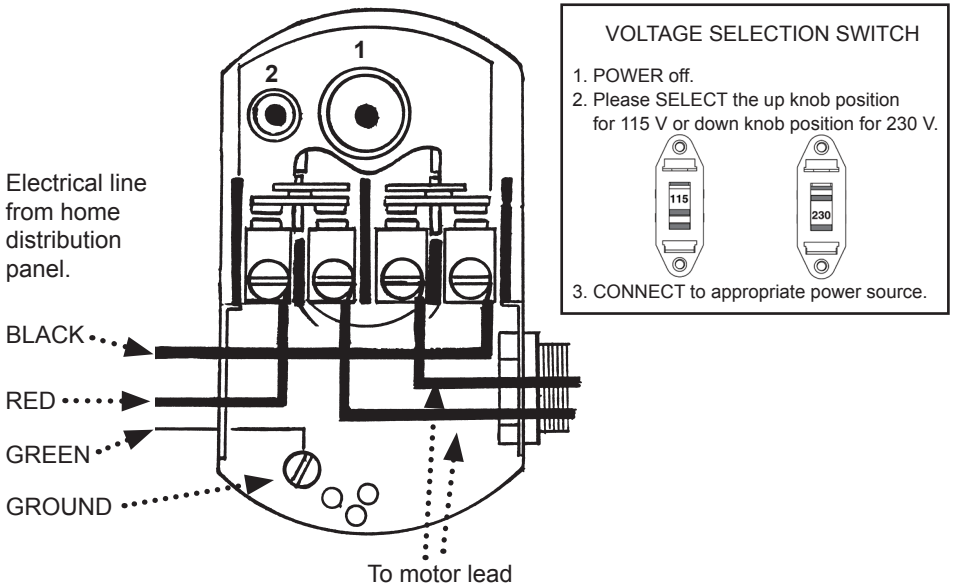

We recommend that a licensed electrician be employed to do the proper wiring to the pressure switch, and to permanently ground the motor in accordance to the electrical codes in your area.

Do not use an extension cord to connect your pump to the power source. From your distribution panel to the pressure switch, we recommend a wire gauge not smaller than 14 gauge.

This is a dual voltage 115/230 pump. The voltage selection switch is located inside the terminal box, on the motor. The motor is factory wired at 115V. For 230V selection, please open the terminal cover and set the switch to the proper voltage. (See above drawing on right).

The pressure switch setting (start/stop 20/40 or 30/50) has been adjusted at the factory. Adjustments may be done to give other operating pressures.

Adjustment or modification of start/stop setting of pressure switch has to be done carefully. **Turn adjustment nut 1 a half turn at a time. (Do not adjust nut 2).**

Turn nut 1 clockwise to raise start and stop pressure setting. **Never turn nut 2. This will change the 20 PSI range between start and stop pressure and may damage your tank's bladder or modify the efficiency of your water system.** Check system operation after each adjustment.

SHALLOW WELL APPLICATION

STEP 5

Install your pump and thread an adaptor into inlet.



STEP 6

Cut poly pipe and connect both ends.

STEP 3

Insert well seal elbow through the seal and attach to pipe.

STEP 4

Install well seal and piping into well casing.

STEP 2

Cut poly pipe and install the check valve.

Well point optional installation

STEP 7

You may install one or more sand points to increase the supply of water.

Check valve,
close to pump.

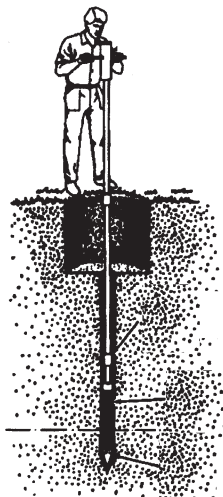
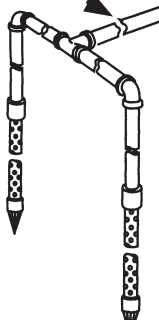

DEEP WELL APPLICATION

STEP 7

Install your pump and thread adaptors into their respective opening.



STEP 8

Cut 1" and 1 1/4" poly pipes and connect both ends.

STEP 5

Insert well seal elbows thru the seal and attach to pipe.

STEP 6

Install well seal and piping into well casing.

STEP 4

Cut 1" and 1 1/4" poly pipes.

STEP 2

Screw 1 1/4" venturi adaptor and 1" adaptor into ejector body.

STEP 3

Install 1" nipple into 1" foot valve, then screw into the ejector.

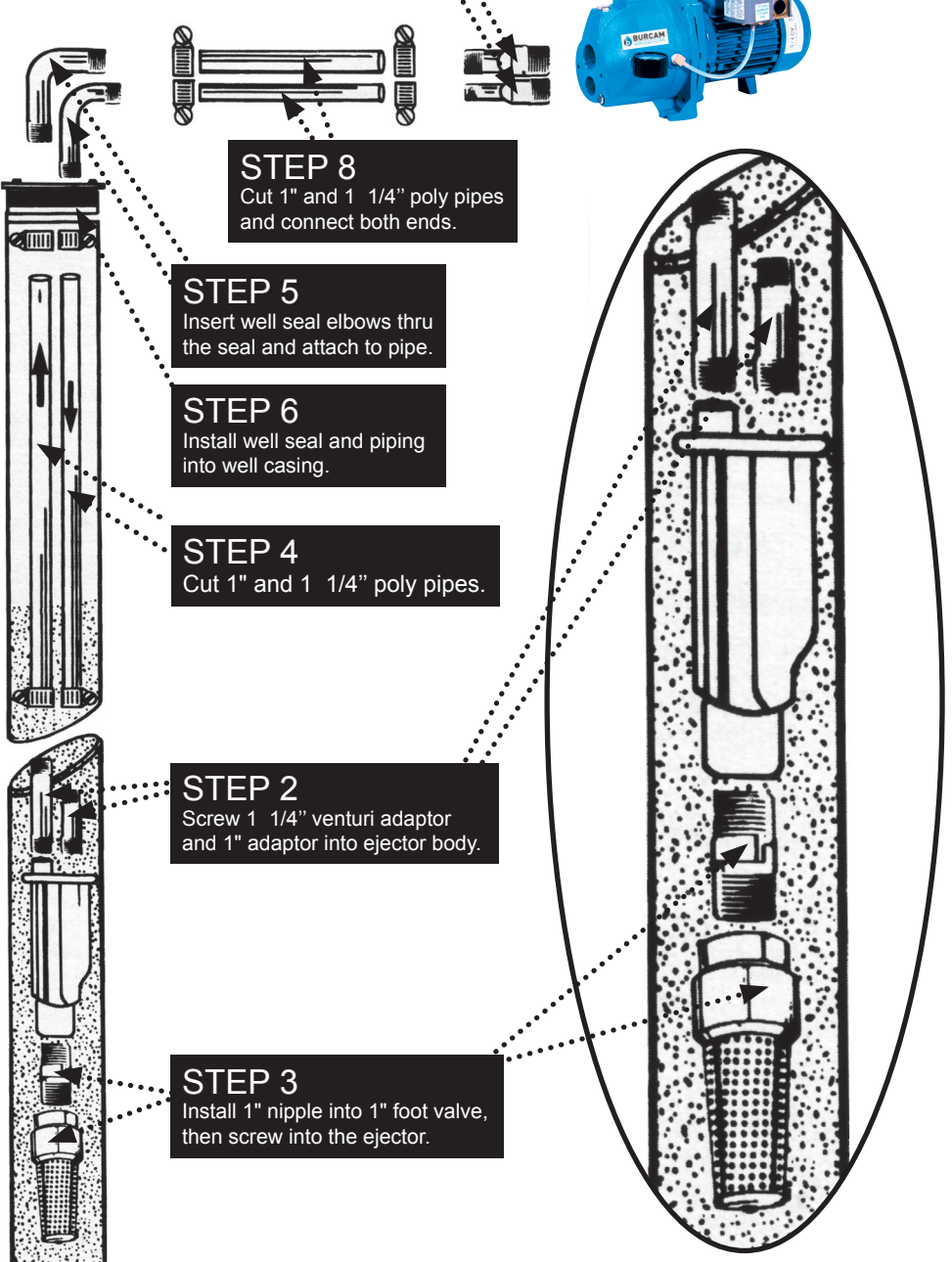

TANK INSTALLATION

Snifter valve to adjust air pressure.

Pressure switch
1/4" connection
if not included
with the pump.

Relief valve
for pumps
with more
than 75 PSI of
capacity 1/2"
connection.

Pressure gauge
1/4" connection.

Drain valve
1/2" connection.

1" MNPT or 3/4"
FNPT connection.

STEP 9

Connect the pump
discharge to the tank 'T'.

From well.

To home's plumbing
distribution line.

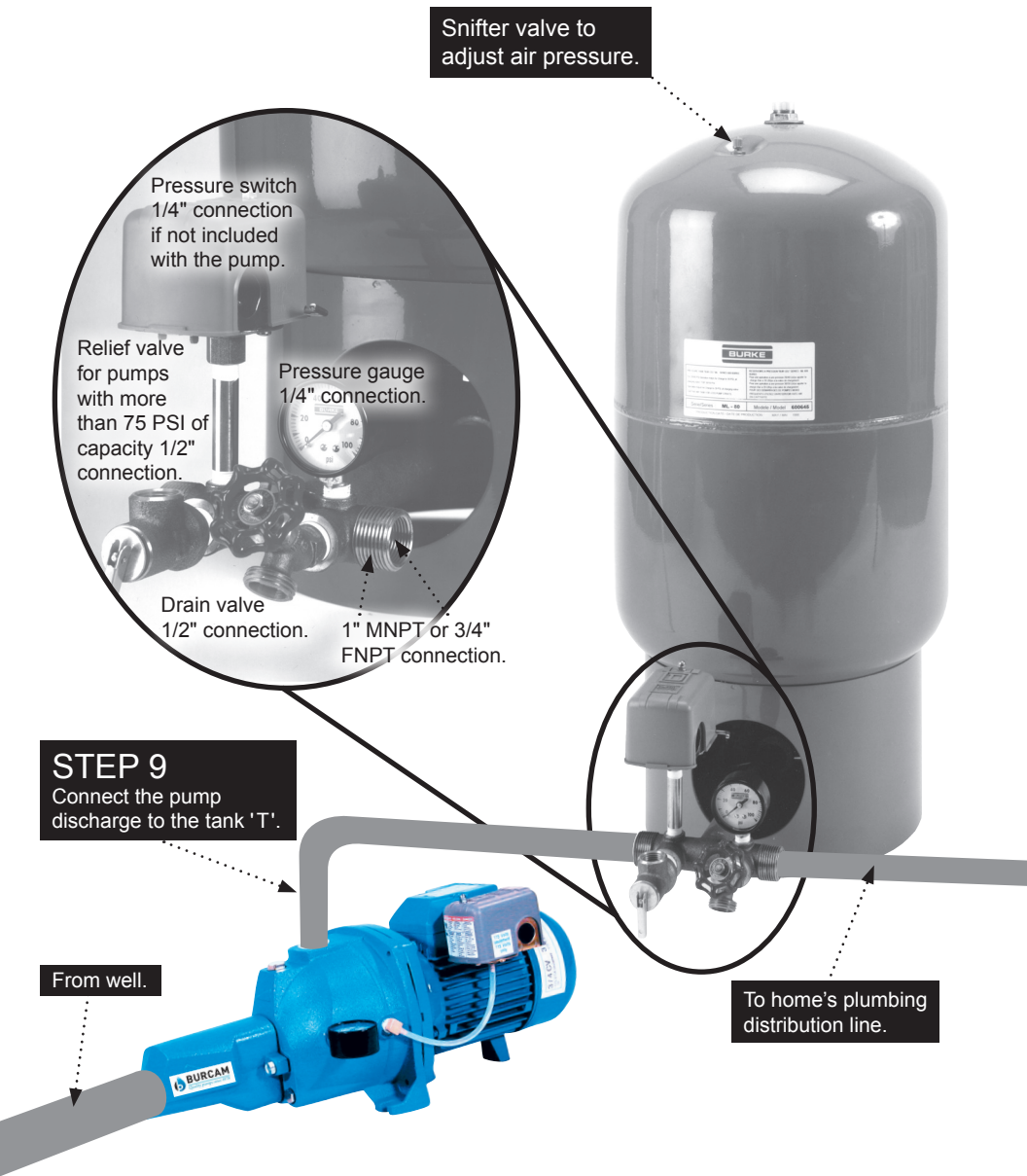

REPAIR PARTS

REF	ITEM	DESCRIPTION	REF	ITEM	DESCRIPTION
1	506014	Junction box cover	18	506317	Diffuser
2	506629	Motor capacitor	19	506298	Diffuser "O" ring
3	506065	Capacitor junction box	20	506300	Priming plug
4	506030W	Stator 1/2HP	21	506400	Priming plug washer
4	506285W	Stator 3/4HP	22	506286	C.I. pump body
5	506297	Pump body cap screw	23	506308W	"O" ring, nozzle and venturi
6	506307	Ejector gasket	24	506306.1	Ejector body (only)
7	506299	Drain plug	25	506312	Motor foot
8	506315	Drain plug washer	26	506031	Pump side motor bearing
9	506022	Impeller nut	27	506314W	Rotor 1/2HP
10	506294P	Impeller 1/2HP	27	506284W	Rotor 3/4HP
10	506292P	Impeller 3/4HP	28	506032	Fan side motor bearing
11	506411	Seal snap ring	29	506296	Motor end bell
12	506026	Sand slinger	30	506017W	Motor fan
13	506415	Ejector body screws (4)	31	506016	Fan cover
14	506289	Pump bracket	32	506094	115/230V selector
15	506287	Seal plate	33	506430	Screws (3)
16	506288	Pump body "O" ring	34	506318W	Impeller shaft key
17	506637	Mechanical seal	35	506419	Cover bolt

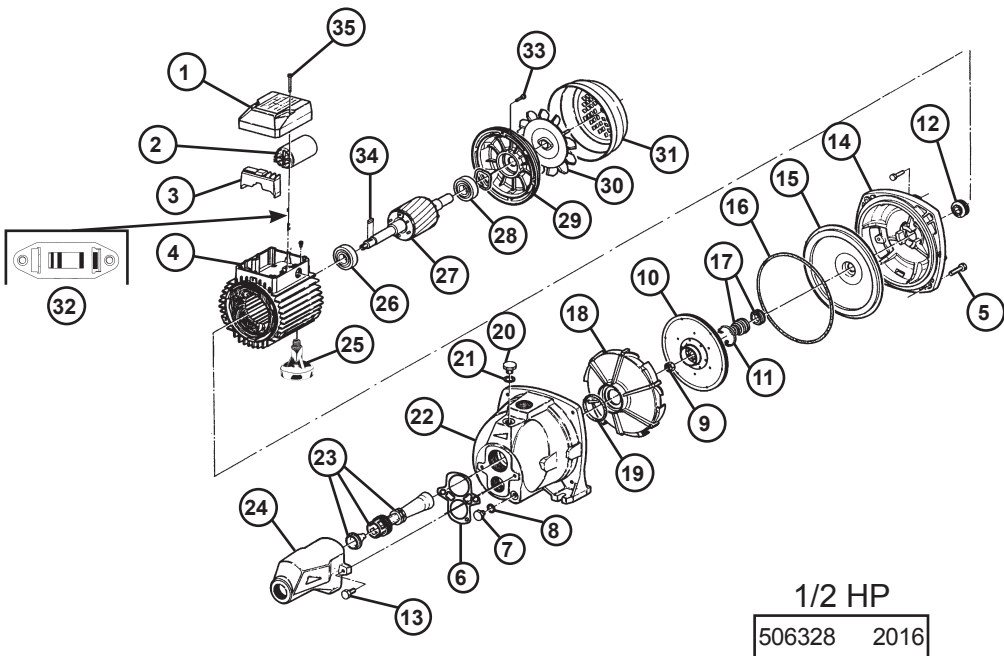

Repair parts may be ordered your authorized point of sale of from
BURCAM PUMPS

TROUBLE SHOOTING GUIDE CHECKLIST

NEVER MAKE ADJUSTMENTS TO ANY ELECTRICAL APPLIANCE OR PRODUCT WITH THE POWER CONNECTED. DON'T JUST UNSCREW THE FUSE OR TRIP THE BREAKER, REMOVE THE POWER FROM THE RECEPTACLE.

TROUBLE	PROBABLE CAUSE	ACTION
Motor does not run.	Switch is off position Blown fuse Tripped breaker Dirty pressure switch Defective pressure switch Defective motor	Turn switch to on position Replace Reset Clean Replace Replace
Motor runs but no water is delivered.	Pump not primed Leaky suction line Foot valve plugged Injector nozzle clogged Water level below foot valve Suction lift to great Improper voltage	Prime with clean water Check pipe and pipe connections Clean Clean Check foot valve level Water level lower than lift capacity Check voltage
Pump does not deliver to full capacity.	Water level below foot valve Injector nozzle clogged Excessive friction in pipe Improper voltage	Check foot valve level Clean Too small or dirty pipe Check voltage
Pump does not shut off.	Leaky discharge line Motor not up to normal speed Improper setting of pressure switch Ejector nozzle clogged	Check all pipes for leak Check power cable and voltage Reset or replace Clean
Pump start stop too often.	Pressure tank waterlogged Leaky foot valve Leaky suction line Foot valve do not close properly Pressure switch out of adjustment Leaky discharge line (toilet etc.)	Drain tank and restart Replace Check pipe and pipe connections Clean or replace Adjust ON/OFF setting Check all pipes for leak
Air spurts from faucets.	Leaky suction line Gaz in water Airlogged tank (galvanized)	Check pipe and pipe connections Check and consult factory Replace air volume control

TO THE END CONSUMER

*If you have any problems with the product, before advising the store, where you've purchased the pump, please contact us at **514 337-4415**, and ask for our sales department, and they will be pleased to help you with any questions you might have, concerning your installation.*